

# Notes on the LaplaCell300

These notes are intended to supplement the information contained within the LaplaCell 300 data sheet.

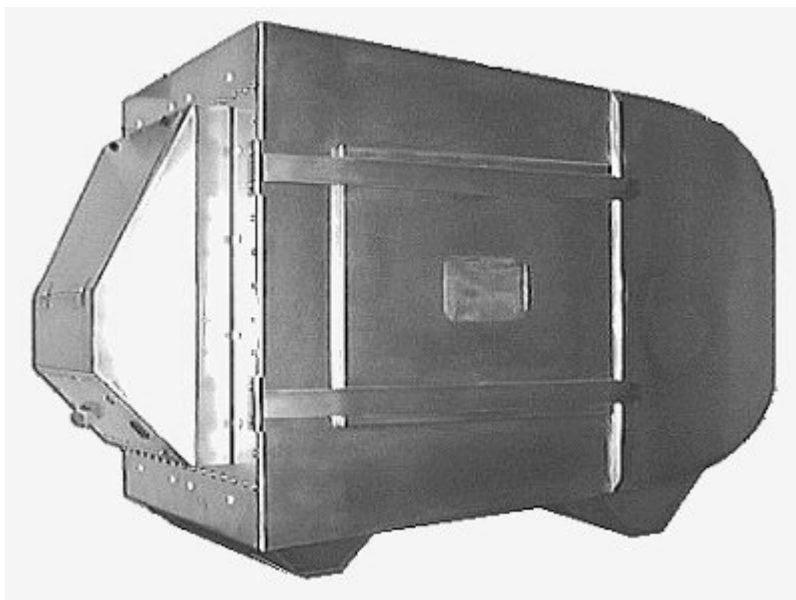

## Construction

The cell is a stainless steel fabrication with continuously welded joints all round, giving a totally screened enclosure which is completely maintenance free and will not degrade with time. The main body of the cell is made from 18swg sheet giving a very strong unit but with an overall weight of only 100kg.

The EUT usable area is contained within a Polypropylene enclosure. No internal parts of the cell are accessible to the user.

The door is fitted with a clear glass window and a fine grade stainless steel mesh for EM screening. Both the glass and the mesh can be easily removed for cleaning.

The periphery of the door mates with a mesh wire EMC gasket in the door frame so that the integrity of the screening is maintained. In the door frame a microswitch is located to detect when the door is not fully closed.

At the nose of the cell, an N type connector and a 5 way DIN connector provide the RF input/output and connections to the internal field sensor respectively.

The RF connector is used as an input from an RF power amplifier for immunity testing. For emissions testing this connector is connected to an emissions analyser.

The 5 way DIN connector provides power to the internal sensor and the DC level back from the sensor to the field control system (normally provided by the RF1000).

Also wired via this connector is the door interlock signal.

## Internal sensor.

This sensor is built into the design of the cell. It is arranged so as to provide an output matched to the field strength as measured in the EUT volume.

Full scale of 2 volts corresponds to 10V/m on standard cells.  
 Alternative models are calibrated to higher field strengths.  
 The field sensor requires a supply of 5V at 20mA.  
 Each cell is shipped fully calibrated for sensor output vs field strength.

## EUT input/output facilities

Comprehensive I/O filter facilities are provided at the rear of the cell. A cable duct between the EUT volume and the filter unit is designed so that cable entry is quick and easy. Inside the filter unit a connection panel with mains socket and a quick connect terminal block are provided. The terminal block can accept up to 12 connections. An additional connector provides an interface for internal lighting and a camera. (Optional extras)

Within the body of the filter unit each connection is RF filtered, then terminated on a matching set of connectors See diagrams.

The standard I/O arrangement comprises:

- Mains supply. IEC input with Mains outlet for EUT (UK, European (Schuko), US or Australian/New Zealand connector. Specify at time of ordering)
- Signals. 12 way Wago quick release terminal block rated at 240V ac 6A each line.
- Connections for internal illumination and camera

Upper part of I/O filter unit showing termination facilities for

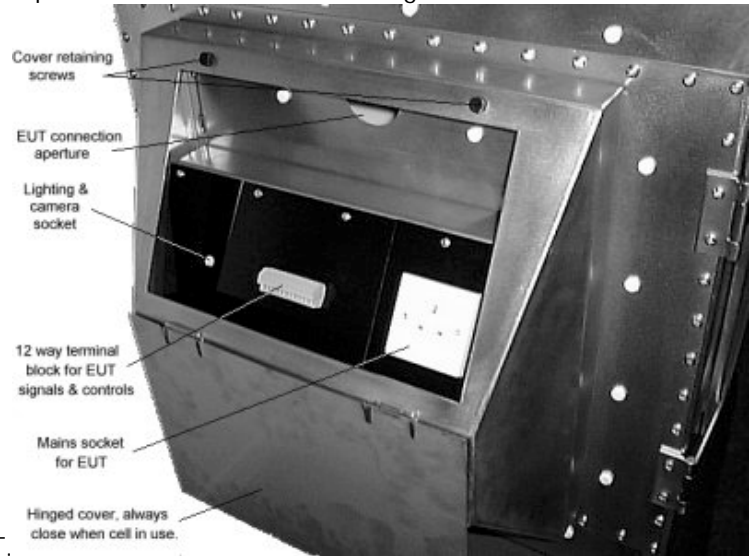

EUT.

Each line is pi-filtered with 5nF to ground. For High Speed data transmission lines, which may be compromised by this capacitance, an alternative common mode inductively filtered system can be provided. A key point is that the I/O facilities can be customised to suit individual requirements at minimal cost. For those EUTs which normally have long I/O cables, the impedance of the filter can be matched to simulate the long length. Again, these requirements can be designed to order.

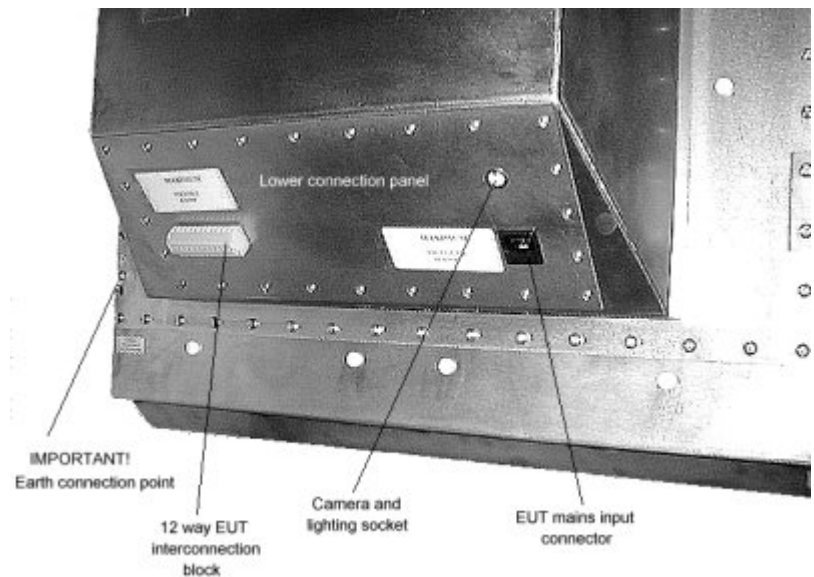

View of connection panel for external cabling.

## Measurements

When making emissions measurements, the EUT should initially be placed on the floor of the test volume, in the centre of the chamber. Cables should be arranged such that they run near vertically from the floor of the EUT test volume to the cable port. This maximises the potential emissions due to cable borne interference.

Cables should be prepared to an appropriate length before attaching to the EUT. Results may become inconsistent if excess cable is allowed to come into contact with the metal walls of the filter box assembly.

Multiple scans should be taken with the EUT in different positions and orientations, as it is possible for the emissions to be directional.

Immunity measurements should be carried out in three perpendicular orientations. The EUT should be tested under the same conditions as for the emissions measurements. An interlock is fitted to the door that inhibits the amplifier output when the door is open. Both door latches should be fastened when closing the door. A mesh window in the door can be used for viewing the EUT during testing. A miniature camera can also be used to monitor the EUT. Connections for a camera are supplied as standard.

## Installation

Before applying power to the chamber, a protective earth must be fitted. A ring terminal has been supplied for this purpose.

Maximum input voltages and currents to the connectors must be observed. Exceeding the stipulated ratings may cause permanent damage to the filter assembly.

The chamber has been designed to be placed on a standard bench or table top. Ensure that the table is capable of supporting the weight of the chamber prior to installation.

## Options

- Alternative I/O interconnections: see above
- Internal lighting: A low voltage lighting unit is available. This is fitted with a vacuum location pad for fitment in any location within the EUT volume.
- Camera: Miniature monochrome camera with screened enclosure complete with exit cable and location pad as for the lighting unit.
- Ventilation unit: The cell can be equipped with forced air ventilation for EUTs which dissipate more than 60W. This system draws air in through the EUT volume and out via the filter unit. Air flow approx. 5litres/sec.

High field strength Up to 200V/m available. Cell fitted with high power balun and absorbing elements. Requires matching high power amplifier.

## Calibration

### Immunity

The field strength inside the EUT volume is within the 6dB range of the set point, at all points throughout the volume. The field is calibrated at 12 points giving an effective coverage of 27 points inside the volume, due to

vertical and horizontal symmetry. The probe used for the calibration is an isometric (non polarised) probe.

A plot of field strength vs probe output is provided with each cell.

## Emissions

Details of the Antenna factor calibration are shown below.

The nominal A.F. is the correction applied to results from the cell to convert them to levels as measured on a three metre OATS. This calibration is obtained by measurements of an Emissions Reference Source (which is a transfer standard from NPL in London) in 12 (effectively 27) locations throughout the EUT volume. The 4 highest readings are averaged to provide the calibration data.

To check the uniformity of the cell, the second plot compares the highest reading and the 4th lowest readings with the A.F. data. This shows excellent correspondence of the A.F. with the highest readings, and results within 10dB at all frequencies. This low reading explains why standard procedure in test cells of all kinds is to move the EUT around the cell and measure the emissions in at least 4 locations.

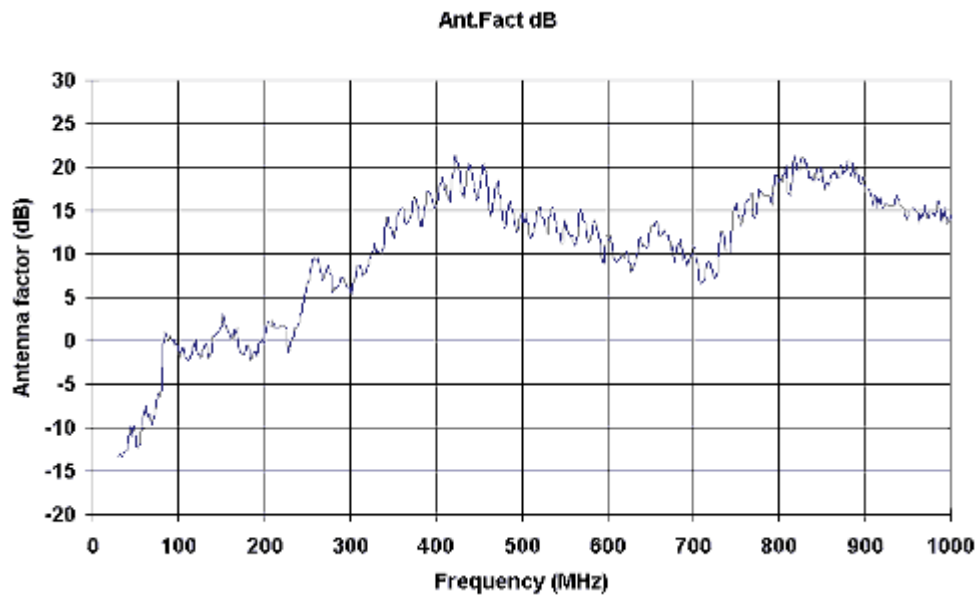

Comparison of highest/lowest A.F. values (Cell 012)

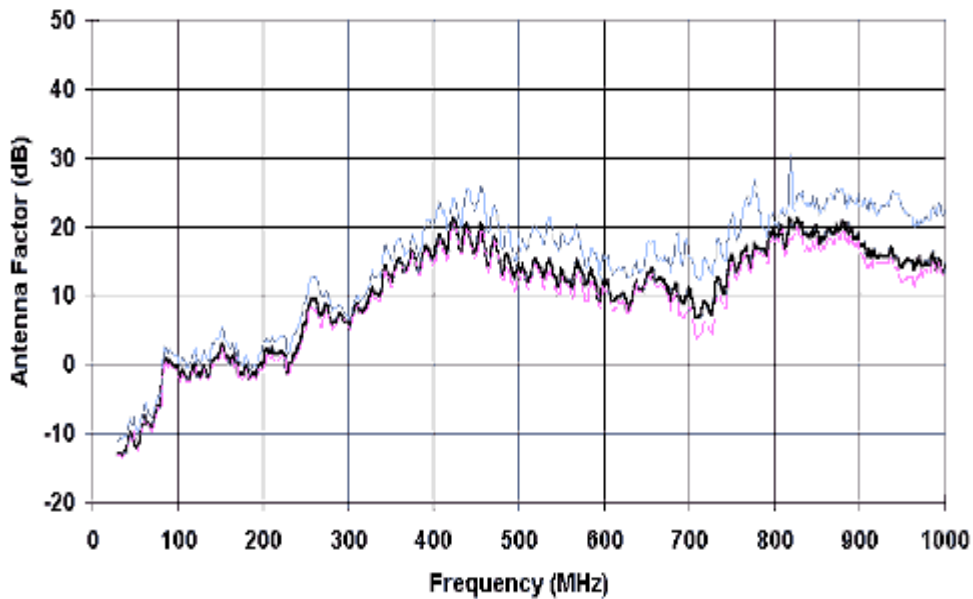

The final chart shows the maximum deviation between the calibrated A.F. and the worst position within the cell.

Max deviation from Nom. A.F. (dB)

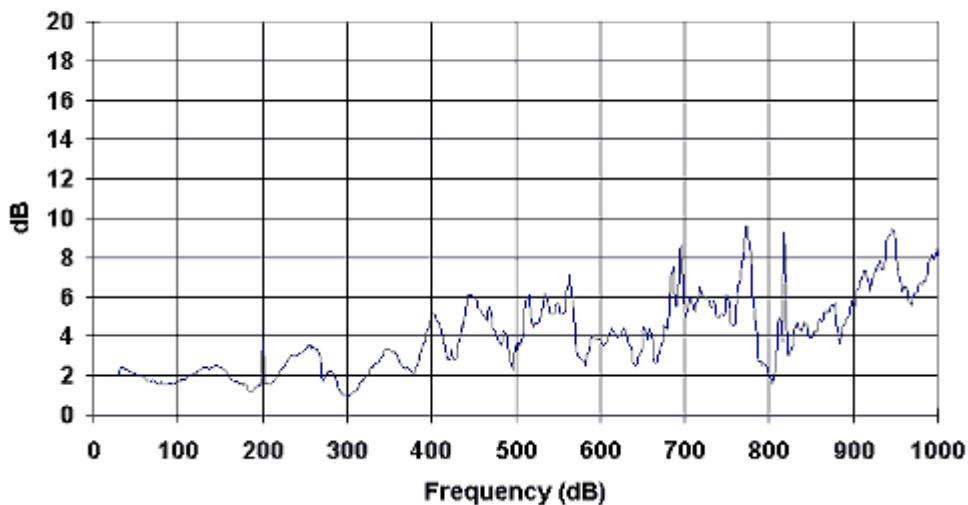

## EUT Control and Monitoring

The RF1000 synthesiser and associated software includes facilities for interfacing to the EUT. Two ports are provided on the synthesiser, one for 'prompting' or controlling the EUT and one for monitoring the status of the EUT.

**Control:** The RF1000 includes a 4 pole c/o relay connected to a 15 way DEE type connector. This relay is controlled from the RF1000 software and can be set to either close continuously during 'dwell' periods, or to pulse at the start of each dwell period. This can be used to trigger appropriate action in the EUT to test its functionality.

**Monitor:** The RF1000 has an input designed for a single external contact closure input. Contact

closed represents EUT OK. This input is monitored by the software and the status displayed on the PC screen. This status can be used to stop the test, or to simply record the status and allow the test to continue.

As each EUT is quite different, it is assumed that the user will (if applicable) build an EUT interface unit specific to the requirements.

## Complete system

The diagram below shows the arrangement for immunity testing.

Each component part of the system can be supplied individually, so for instance, the RF1000 can be used with a third party amplifier and cell.

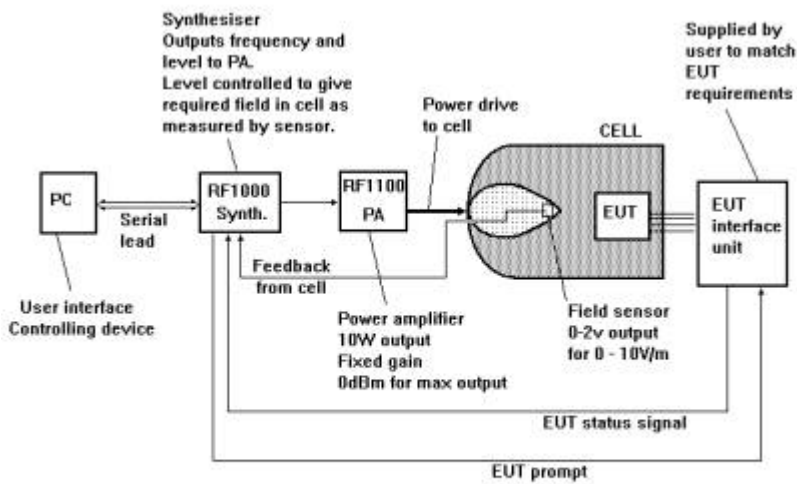

General arrangement - RF Immunity test system